

DURO-PT® THREAD-CUTTING FASTENERS

The Duro-PT® thread-cutting fastener is engineered to meet the demanding requirements of thermoset plastics, easing assembly and ensuring a strong, reliable joint to maximize assembly performance.

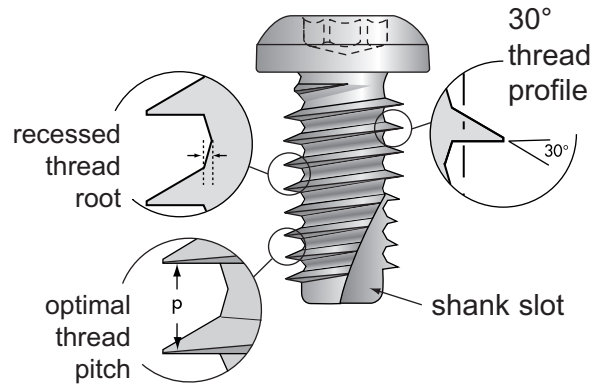

Duro-PT® Thread-Cutting Fastener



SPECIFICATIONS

Sizes • S22 to S80 in diameter; up to 152mm under head. Other sizes may be available upon request.

Head Styles • Pan, flat, hex, round washer, hex washer, oval, button head, fillister

Specials • Shoulder screws, sems, double end studs, collar studs; others as required

Drive Systems • TORX PLUS® Drive System is recommended to facilitate the proper amount of torque transfer required for cutting threads. Other styles are available.

APPLICATIONS

Thermoset plastics

KEY ADVANTAGES

- Cuts threads in stiffer plastics
- Minimizes installation torque
- Maximizes assembly performance

FEATURES & BENEFITS

Asymmetrical 30° thread profile, inclined towards load surface to increase friction (FR) between the application and the fastener

- Reduces radial stress
- Reduces back-out caused by relaxation
- Increases strip resistance
- Eliminates need for supplementary locking devices

Optimal thread pitch for deeper thread engagement

- Increases pull-out strength
- Increases resistance to vibration loosening
- Increases load-carrying capability

Recessed thread root provides space for displaced material

- Minimizes installation torque
- Minimizes risk of clogging and galling of threads during assembly

Shank slot minimizes chip production

Through hardened to Rc 33-39

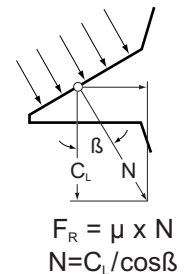

DURO-PT® THREAD-CUTTING FASTENERS

BOSS DESIGN RECOMMENDATIONS

Laboratory testing and service applications have produced the general recommendations shown. Specific applications may, however, require some modification in order to allow for:

- molding conditions
- mold tool design
- type of resin
- type of filler
- material density

DETERMINING OPTIMUM BOSS & HOLE SIZES

A hole diameter of .85d to .89d is permissible for most thermoset applications. In order to properly determine boss and hole sizes, it is recommended that testing be done on several different hole sizes. This will allow you to determine the optimum drive-to-strip ratio that is required for your application.

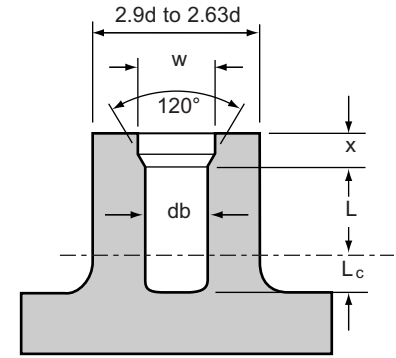

d = nominal screw diameter

BOSS COUNTERBORE SIZE

High tightening torques and large tensile stresses may cause a cone-shaped expansion and failure at the bottom of the boss. Designing the boss with the appropriate counterbore (CB) reduces edge stress and alleviates cracking.

CB depth: $x = 0.5d$
 CB width: $w = 1.08 x d$

LENGTH OF ENGAGEMENT

The length of engagement (L) should be 2 to 3 times the nominal screw diameter. This calculation should exclude counterbore depth.

CHIP SPACE DEPTH

The depth of space (L_c) for chips removed during thread cutting operations should be between 0.8 and 1.2 the nominal screw diameter.

BOSS HOLE DIAMETER (db) d = nominal screw diameter

Size	.85d		.86d		.87d		.88d		.89d	
	mm	in.	mm	in.	mm	in.	mm	in.	mm	in.
S22	1.87	.074	1.89	.074	1.91	.075	1.94	.076	1.96	.077
S25	2.12	.083	2.15	.085	2.17	.085	2.20	.087	2.23	.088
S30	2.55	.100	2.58	.102	2.61	.103	2.64	.104	2.67	.105
S35	2.97	.117	3.01	.119	3.04	.120	3.08	.121	3.12	.123
S40	3.40	.134	3.44	.135	3.48	.137	3.52	.139	3.56	.140
S50	4.25	.167	4.30	.169	4.35	.172	4.40	.173	4.45	.175
S60	5.10	.201	5.16	.203	5.22	.206	5.28	.208	5.34	.210
S70	5.95	.234	6.02	.237	6.09	.240	6.16	.243	6.23	.245
S80	6.80	.268	6.88	.271	6.96	.274	7.04	.277	7.12	.280

BOSS OUTER DIAMETER (O.D.) d = nominal screw diameter

Size	.85d		.86d		.87d		.88d		.89d	
	mm	in.	mm	in.	mm	in.	mm	in.	mm	in.
S22	6.38	.251	6.23	.245	6.09	.240	5.94	.234	5.79	.228
S25	7.25	.285	7.08	.279	6.92	.272	6.75	.266	6.58	.259
S30	8.70	.343	8.50	.335	8.30	.327	8.10	.319	7.90	.311
S35	10.15	.400	9.92	.391	9.68	.381	9.45	.372	9.21	.363
S40	11.60	.457	11.33	.446	11.07	.436	10.25	.425	10.53	.415
S50	14.50	.571	14.15	.557	13.83	.544	13.50	.531	13.17	.519
S60	17.40	.685	17.00	.669	16.60	.654	16.20	.638	15.80	.622
S70	20.30	.799	19.38	.781	19.37	.763	18.90	.744	18.43	.726
S80	23.20	.913	22.67	.893	22.13	.871	21.60	.850	21.07	.830

DURO-PT® THREAD-CUTTING FASTENERS

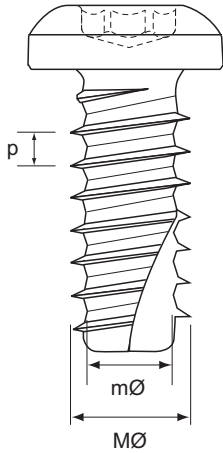

DIMENSIONAL DATA

Nom. Size	Metric Size	Thread Pitch (mm)	MØ Major Diameter (mm)	mØ Minor Diameter (mm)
S22	M2.2	0.71	2.20	1.59
S25	M2.5	0.77	2.50	1.81
S30	M3	0.86	3.00	2.18
S35	M3.5	0.95	3.50	2.56
S40	M4	1.04	4.00	2.93
S50	M5	1.23	5.00	3.68
S60	M6	1.42	6.00	4.42
S70	M7	1.60	7.00	5.20
S80	M8	1.79	8.00	5.91

HOLE SIZES PER PERCENTAGE OF THREAD ENGAGEMENT

Size	100%		90%		80%		70%		60%		50%		40%	
	mm	in.	mm	in.	mm	in.	mm	in.	mm	in.	mm	in.	mm	in.
S22	1.71	.067	1.77	.070	1.83	.072	1.88	.074	1.94	.076	1.99	.078	2.05	.081
S25	1.95	.077	2.01	.079	2.07	.082	2.13	.084	2.20	.086	2.26	.089	2.32	.091
S30	2.34	.092	2.41	.095	2.48	.098	2.56	.101	2.63	.104	2.70	.106	2.78	.109
S35	2.73	.107	2.81	.111	2.90	.114	2.99	.118	3.07	.121	3.16	.124	3.24	.128
S40	3.12	.123	3.21	.127	3.31	.130	3.41	.134	3.51	.138	3.60	.142	3.70	.146
S50	3.90	.153	4.01	.158	4.13	.163	4.25	.167	4.37	.172	4.49	.177	4.61	.182
S60	4.67	.184	4.82	.190	4.96	.195	5.10	.201	5.24	.206	5.38	.212	5.52	.217
S70	5.45	.215	5.62	.221	5.78	.228	5.95	.234	6.12	.241	6.28	.247	6.45	.254
S80	6.23	.245	6.42	.253	6.61	.260	6.80	.268	6.98	.275	7.17	.282	7.36	.290

SUGGESTED THREAD ENGAGEMENT

Based on testing and past performance, a thread engagement of 50% to 60% is recommended. For optimal fastener performance, please contact an Acument™ Global Technologies applications engineer. See following page for boss design recommendations.



6125 Eighteen Mile Road
Sterling Heights, Michigan 48314

1.800.544.6117

acument.com

camcarsolutions.com

ringscrew.com